

## Nominal data

Type	612 NNI	
Nominal voltage	VDC	12
Nominal voltage range	VDC	8 .. 12.6
Speed	min <sup>-1</sup>	5100
Power input	W	1.5
Min. ambient temperature	°C	-20
Max. ambient temperature	°C	65
Air flow	m <sup>3</sup> /h	41
Sound power level	B	5.0
Sound pressure level	dB(A)	35

ml = Max. load · me = Max. efficiency · fa = Running at free air · cs = Customer specs · cu = Customer unit  
Subject to alterations

### Technical features

<b>Housing material</b>	Fibreglass-reinforced plastic (PBT)
<b>Impeller material</b>	Fibreglass-reinforced plastic (PA)
<b>Mass</b>	0.066 kg
<b>Dimensions</b>	60 x 60 x 25 mm
<b>Direction of air flow</b>	Air exhaust over bars
<b>Direction of rotation</b>	Right, looking at rotor
<b>Bearing</b>	Ball bearings
<b>Lifetime L10 at 40 °C</b>	70000 h
<b>Lifetime L10 at maximum temperature</b>	40000 h
<b>Connection line</b>	Single strands AWG 22, TR 64, bared and tin-plated.
<b>Motor protection</b>	Protected against reverse polarity and locking.
<b>Locked-rotor protection</b>	With electronic blocking and overload protection
<b>Approval</b>	VDE, CSA, UL, CE
<b>Option</b>	Special options: Speed signal Go / No-go alarm External temperature sensor Internal temperature sensor Moisture protection

612 NNI

# DC axial compact fan

## Product drawing

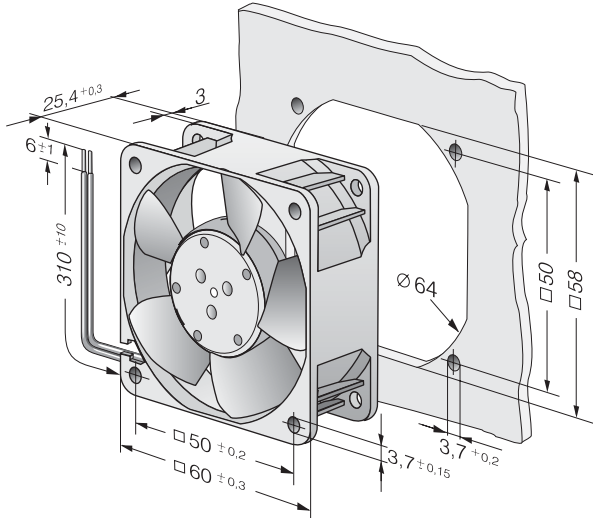

## Charts

